

# S Oil Bath Air Cleaners



The S series is a highly efficient Oil Bath Air Cleaner, which has a horizontal tubular outlet for use with a hose. It is designed to be mounted vertically with the assistance of a Saddle Bracket.

## Vortex Air Technology S and SA Oil Bath Air Cleaners

The S and SA Oil Bath Air Cleaners are smaller and light weight than the G or GA, requiring less space for mounting. Both S and SA styles are made of three units: the Body Assembly, Vortex Chamber, and Cup. The air is first centrifugated by the Vortex Chamber to separate large particles of dust. Air then flows into the filter element located in the Body Assembly, along with oil from the oil reservoir. Dust is suspended in the air. Clean air passes through the filter and the dusty oil drains back to the Cup.

Also available:



G w/Clamps



G w/Rods



GA



SA

## Oil Bath Air Cleaners - S Series

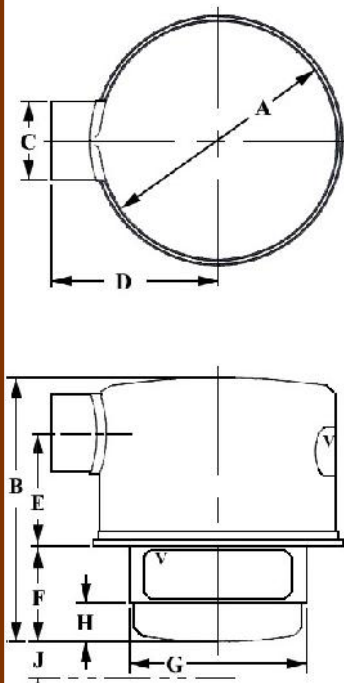

Model No.	Rated Airflow C.F.M.	Oil Cap. Pints	A (In.)	B (In.)	C (In.)	D* (In.)	E (In.)	F (In.)	G (In.)	H (In.)	J (In.)	Net Wt. LBS
S50	63	1.20	5.31	9.02	1.50	3.93	3.43	4.27	4.07	2.41	1.50	2.60
S60	100	0.70	6.12	6.68	2.00	4.31	3.42	2.44	4.56	0.96	0.50	2.80
S60AA	100	0.70	6.12	6.68	2.00	5.37	2.80	2.44	4.56	0.96	0.50	2.80
S78	160	1.00	7.80	7.25	2.50	5.12	3.31	2.25	5.56	0.97	0.50	4.80
S90	240	1.80	9.06	8.25	2.50	5.75	3.46	3.00	6.56	1.00	0.62	6.40
S110	425	3.50	11.00	12.75	3.50	7.00	5.18	5.25	8.03	1.25	1.75	15.00
S110E	370	3.50	11.00	12.75	3.00	7.00	5.31	5.25	8.03	1.25	1.75	11.50
S120	540	5.80	12.00	13.88	3.50	8.00	7.25	4.25	10.00	1.13	2.38	19.50

\* Other Tube Dimensions Available